



# REGOLO GENERAL WARNING



## WARNING:

DO NOT ASSEMBLE CONTINUOUS RUN ON THE GROUND AND LIFT INTO PLACE.  
JOINTS WILL DISTORT AND NOT CREATE A TIGHT FIT.  
JOINING HARDWARE WILL HAVE TO BE PURCHASED AND REPLACED.

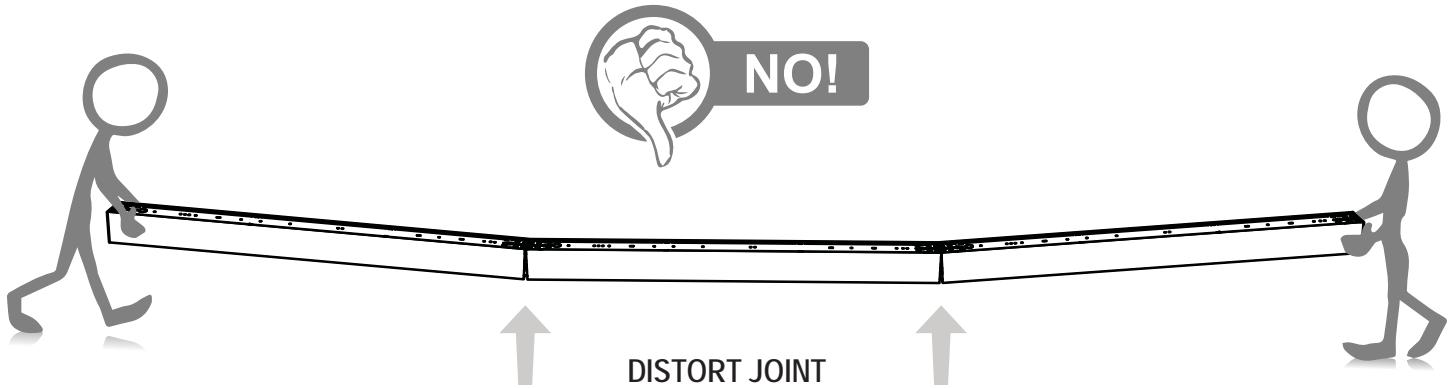

FOR PROPER INSTALL INFORMATION SEE  
RESPECTIVE SERIES INSTALLATION INSTRUCTIONS.

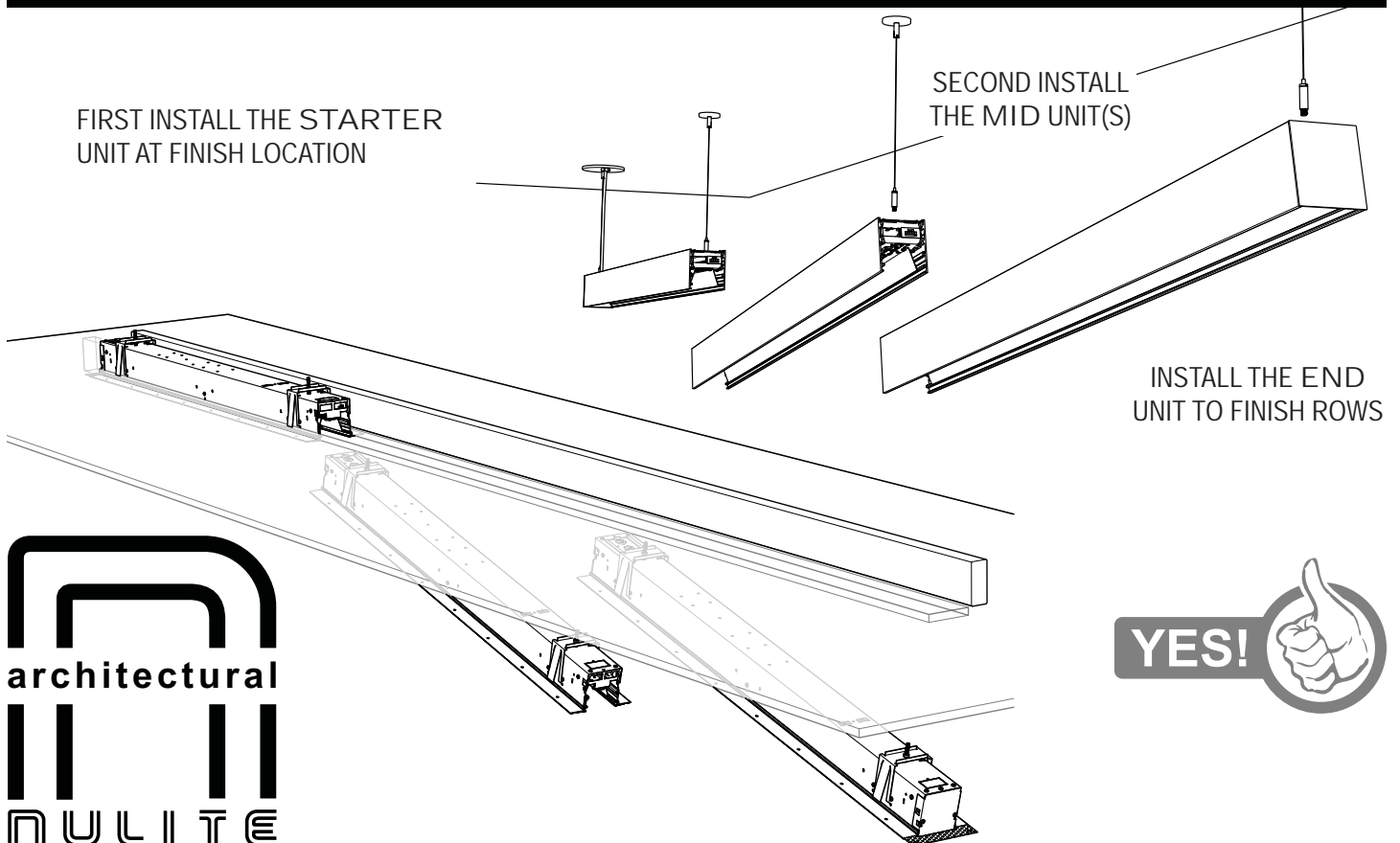

10770 East 51st Ave, Denver, CO 80239 - Phone (303)287-9646 Fax (303)287-0316

*Instructions and dimensions are subject to change without notification. Instruction sheets on our website supersede all other versions.*

2016 Rev. A

**SURFACE - INSTALLATION and MAINTENANCE INSTRUCTIONS REGOLO Series**

**ROW INSTALLATION**

7

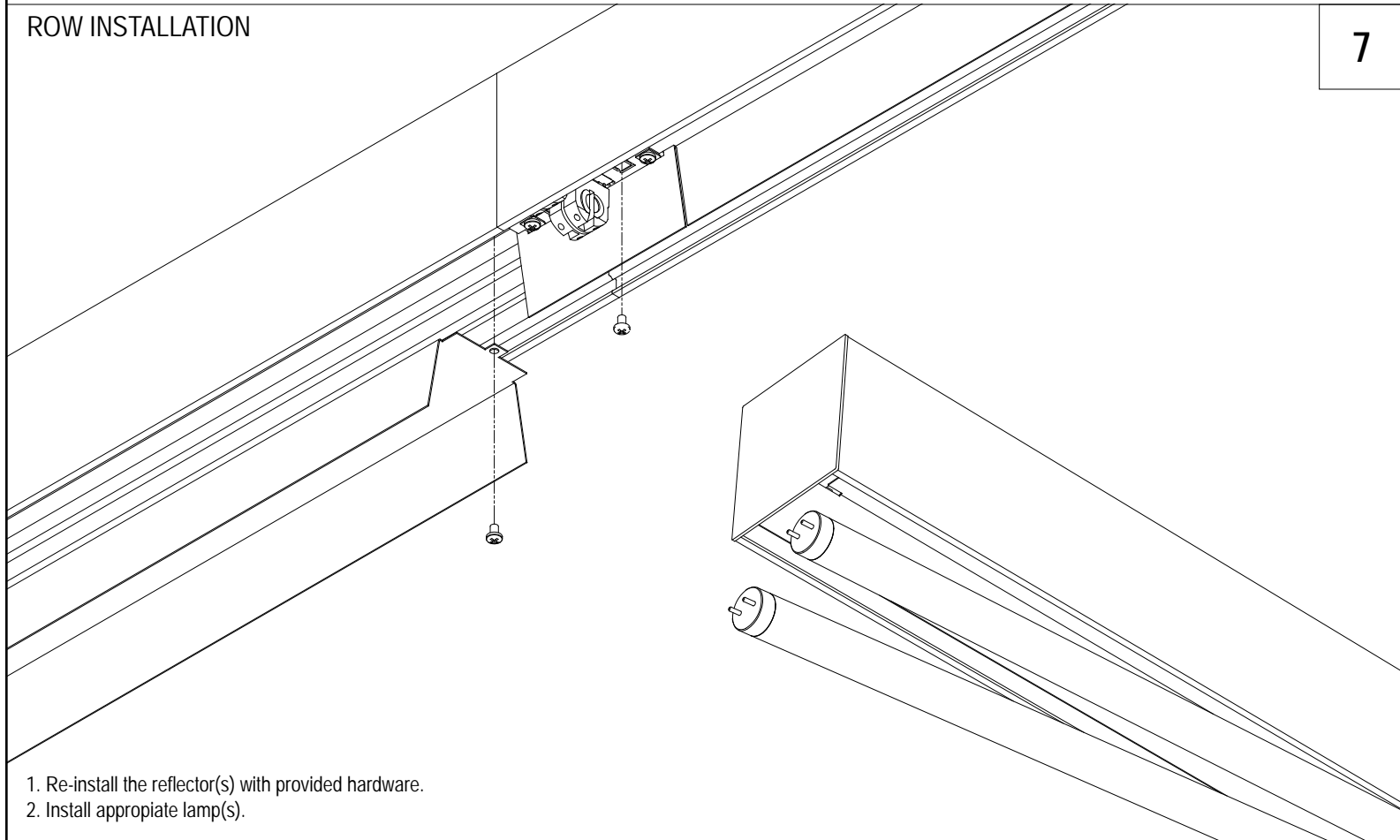

1. Re-install the reflector(s) with provided hardware.
2. Install appropriate lamp(s).

**ROW INSTALLATION**

8

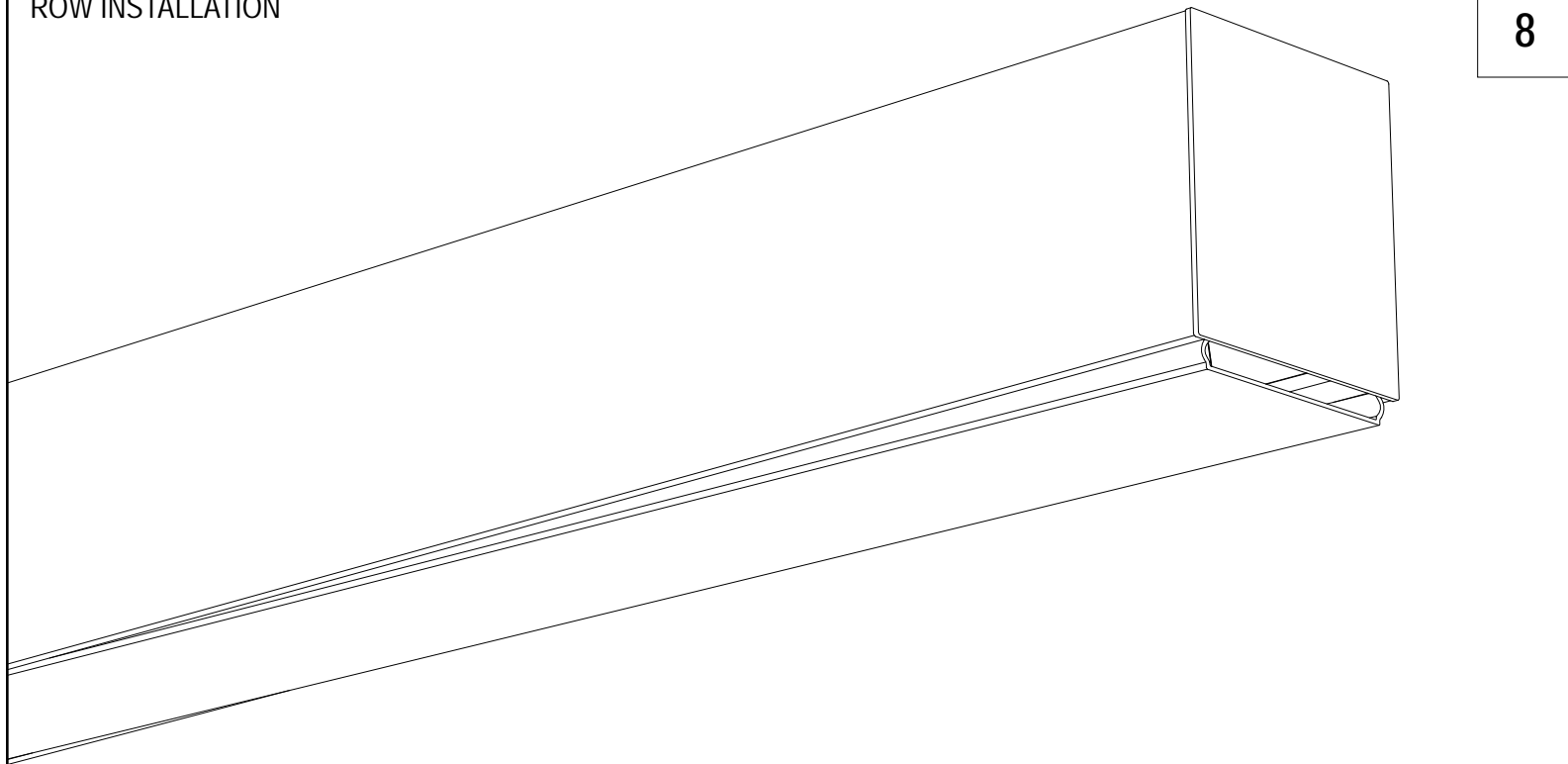

1. Re-install the lens. Gently snap the lens in at one end. Slide hand along lens to snap entire length into place.
3. Clean - Wipe down luminaire with a clean damp rag.
4. Connect power and make sure luminaire works properly.

**SURFACE - INSTALLATION and MAINTENANCE INSTRUCTIONS REGOLO Series**

**NON- STAGGERED ROW MOUNTED LUMINAIRE (FLUORESCENT)**

APPLIES TO:  
- ALL SURFACE MOUNTING SITUATIONS

**WARNINGS**  
RISK OF ELECTRICAL SHOCK OR FIRE - DISCONNECT POWER DURING INSTALLATION / SERVICING.  
READ ALL INSTRUCTIONS COMPLETELY BEFORE STARTING INSTALLATION.  
INSTALL & WIRE IN ACCORDANCE TO ALL NATIONAL & LOCAL CODES BY A CERTIFIED ELECTRICIAN.  
FIXTURE MAY BE SHARP - HANDLE WITH CARE.  
LET FIXTURE COOL BEFORE MAINTENANCE.

**ROW INSTALLATION PARTS**

1

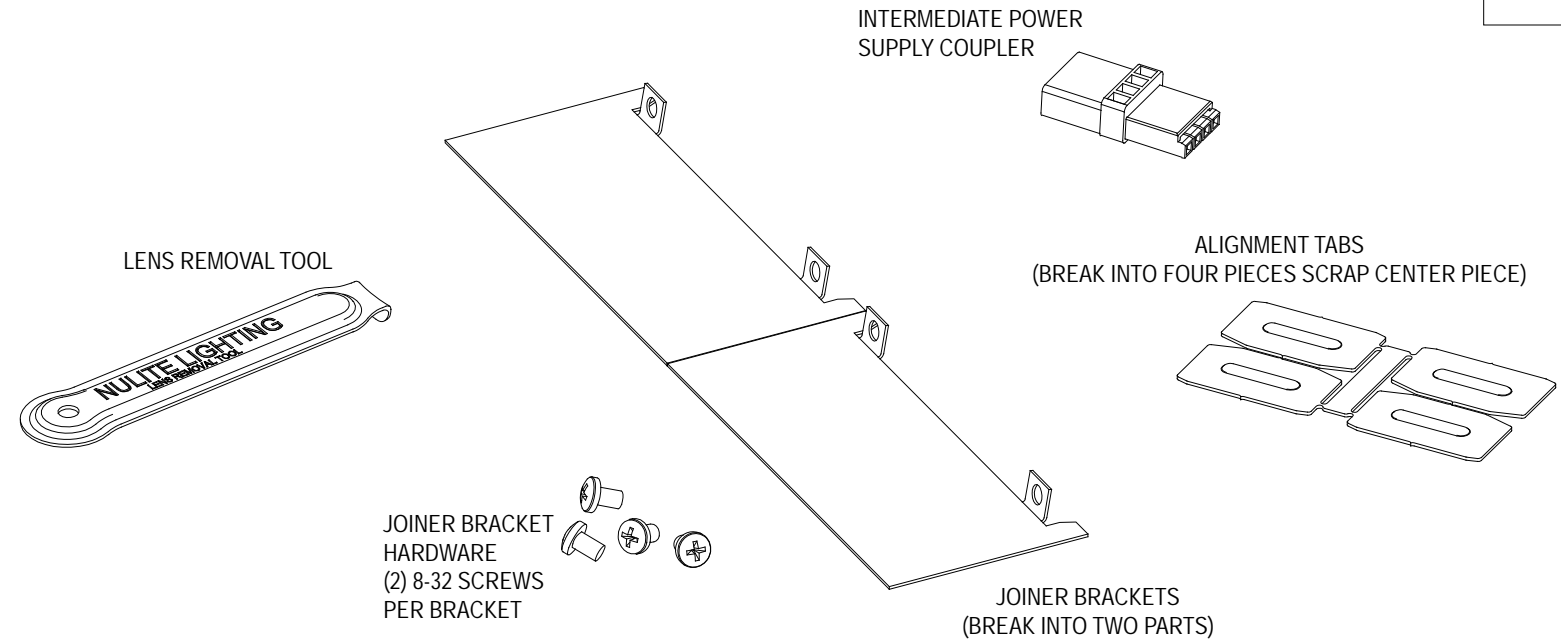

**ROW EXPLODED VIEW**

2

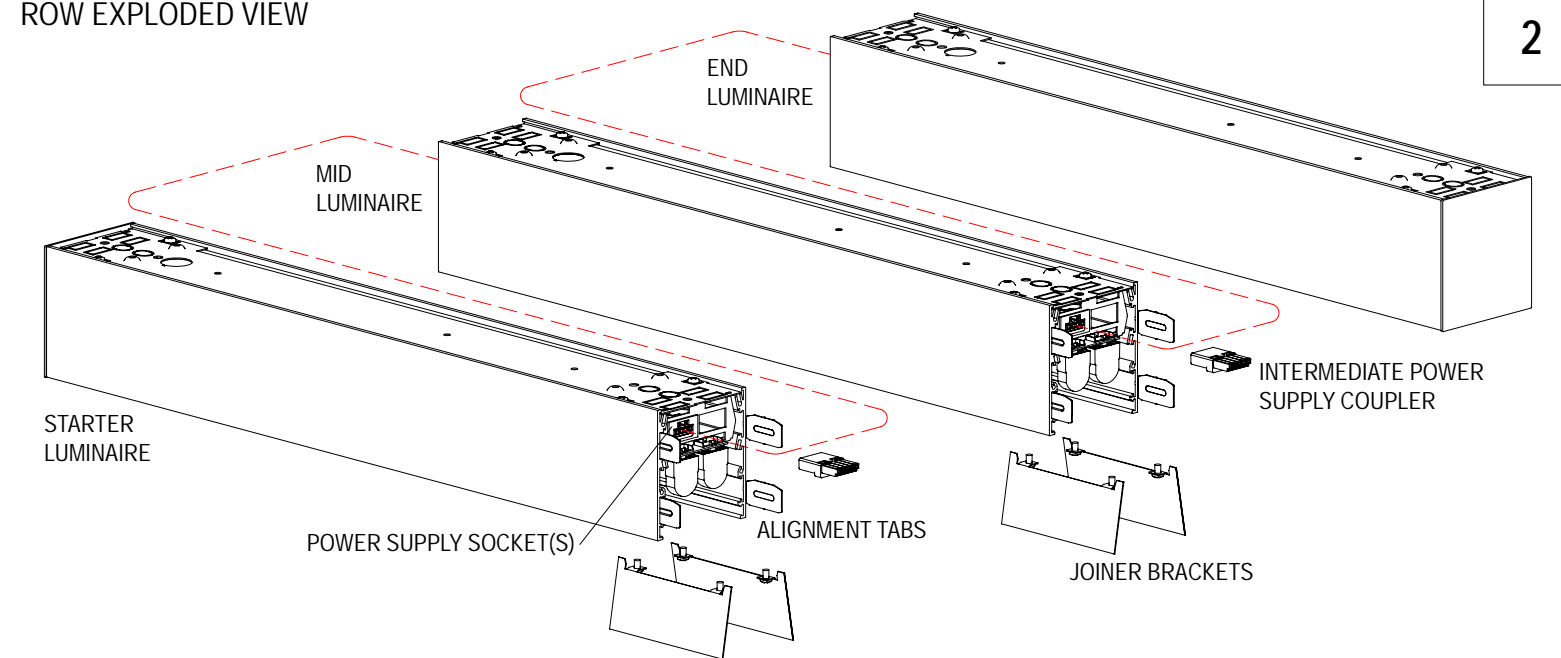

1. Remove all packaging prior to installation.
2. The row assembly must start with the "STARTER" luminaire and end with the "END".
3. One set of row installation parts are provided for each joint.

**SURFACE - INSTALLATION and MAINTENANCE INSTRUCTIONS REGOLO Series**

**LAMP INSTALLATION, MAINTENANCE and CLEANING**

3

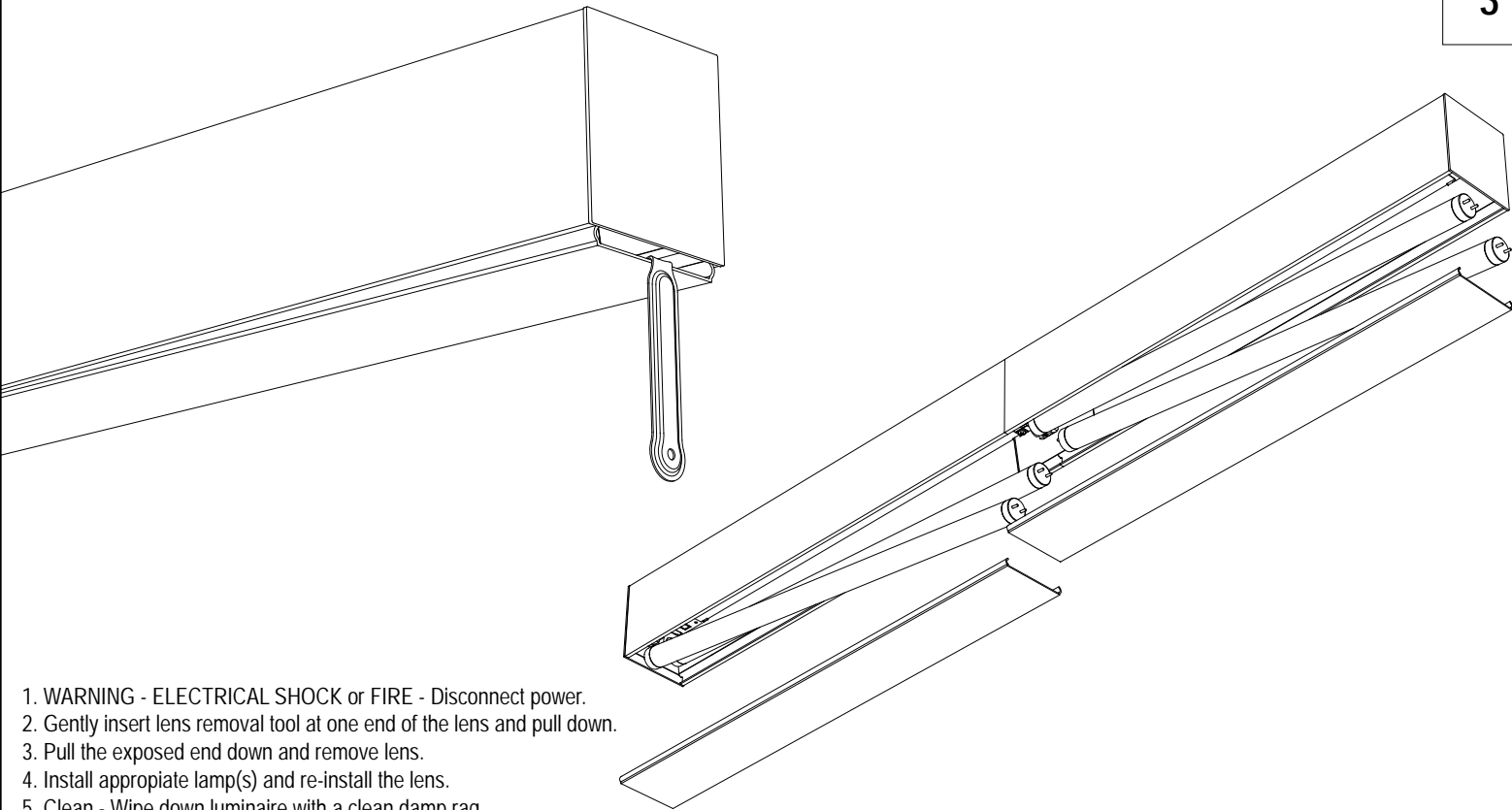

1. WARNING - ELECTRICAL SHOCK or FIRE - Disconnect power.
2. Gently insert lens removal tool at one end of the lens and pull down.
3. Pull the exposed end down and remove lens.
4. Install appropriate lamp(s) and re-install the lens.
5. Clean - Wipe down luminaire with a clean damp rag.
6. Connect power and make sure luminaire works properly.

**ACCESS TO WIRE WAY**

4

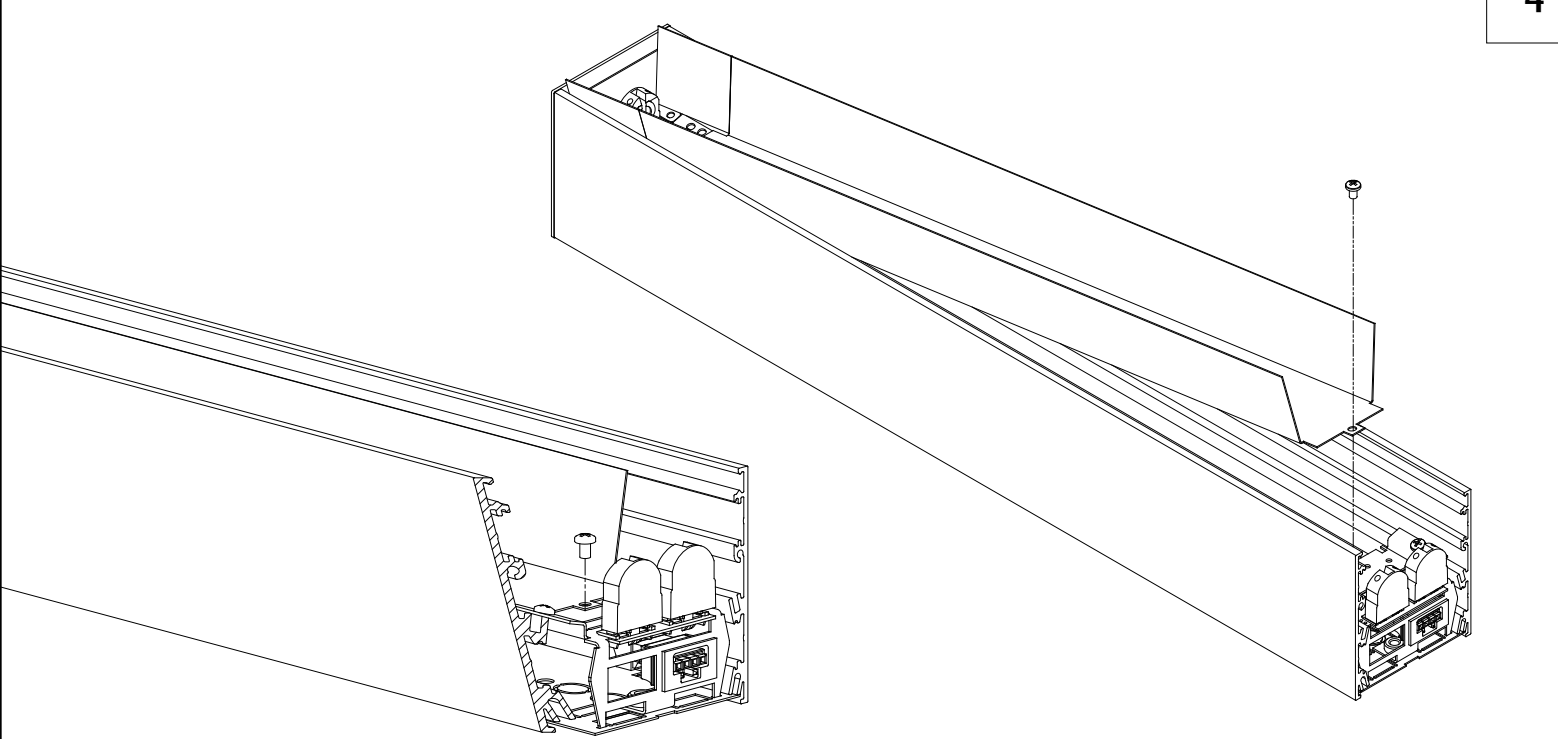

1. Store the lens in a safe place during installation.
2. Remove lamp(s) if applicable to expose the reflector.
3. To access the ballast channel remove one screw then shift the reflector over and rotate out. Store the reflector in a safe place during installation

**SURFACE - INSTALLATION and MAINTENANCE INSTRUCTIONS REGOLO Series**

**PLAN VIEW OF HOUSING BACK**

5

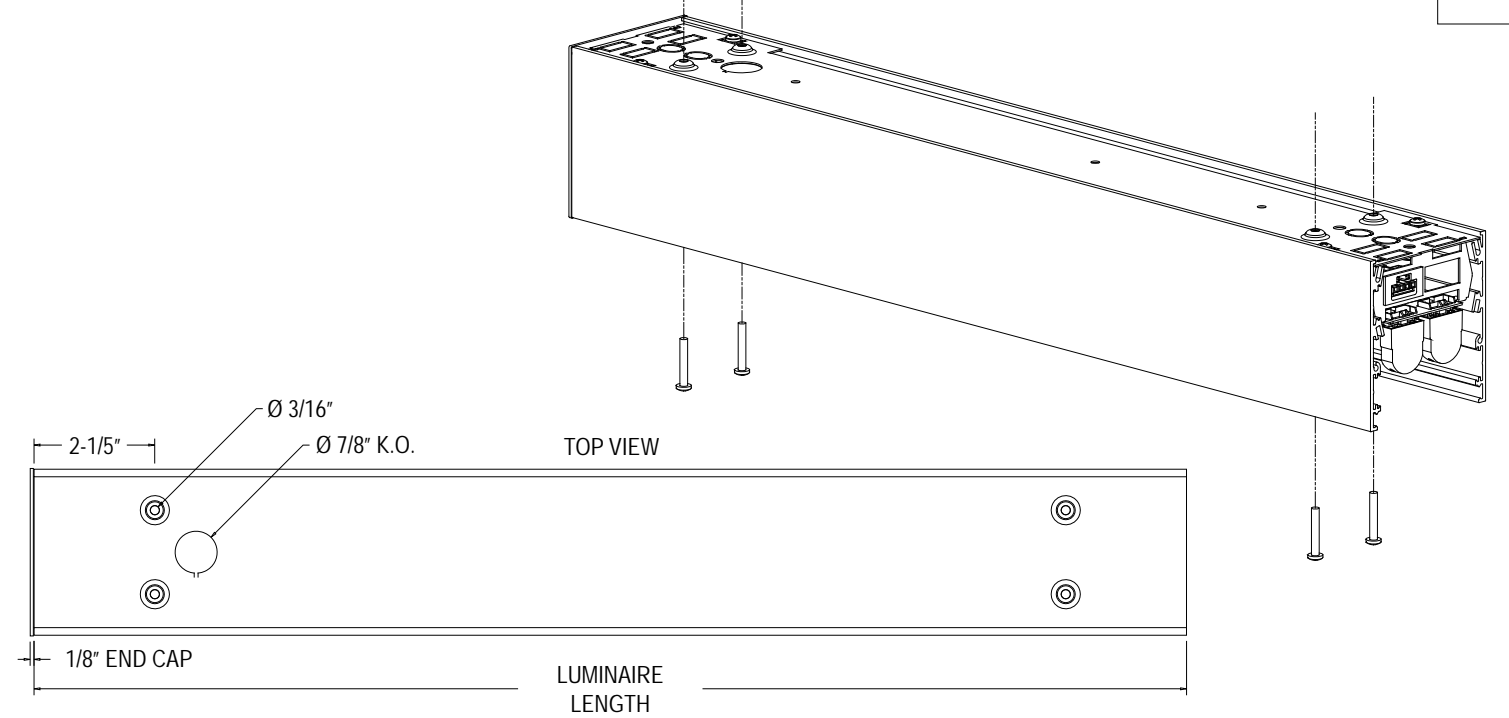

1. WARNING - ELECTRICAL SHOCK or FIRE - Disconnect power.
2. Wire per all National and Local electrical codes. Locate and remove desired knock-outs on the back of luminaire for power.
3. Locate the four mounting dimples with holes. Layout and install the "starter" luminaire using four holes provided. Mount luminaire to desired surface with adequate hardware. Mounting hardware is not included.

**ROW INSTALLATION**

6

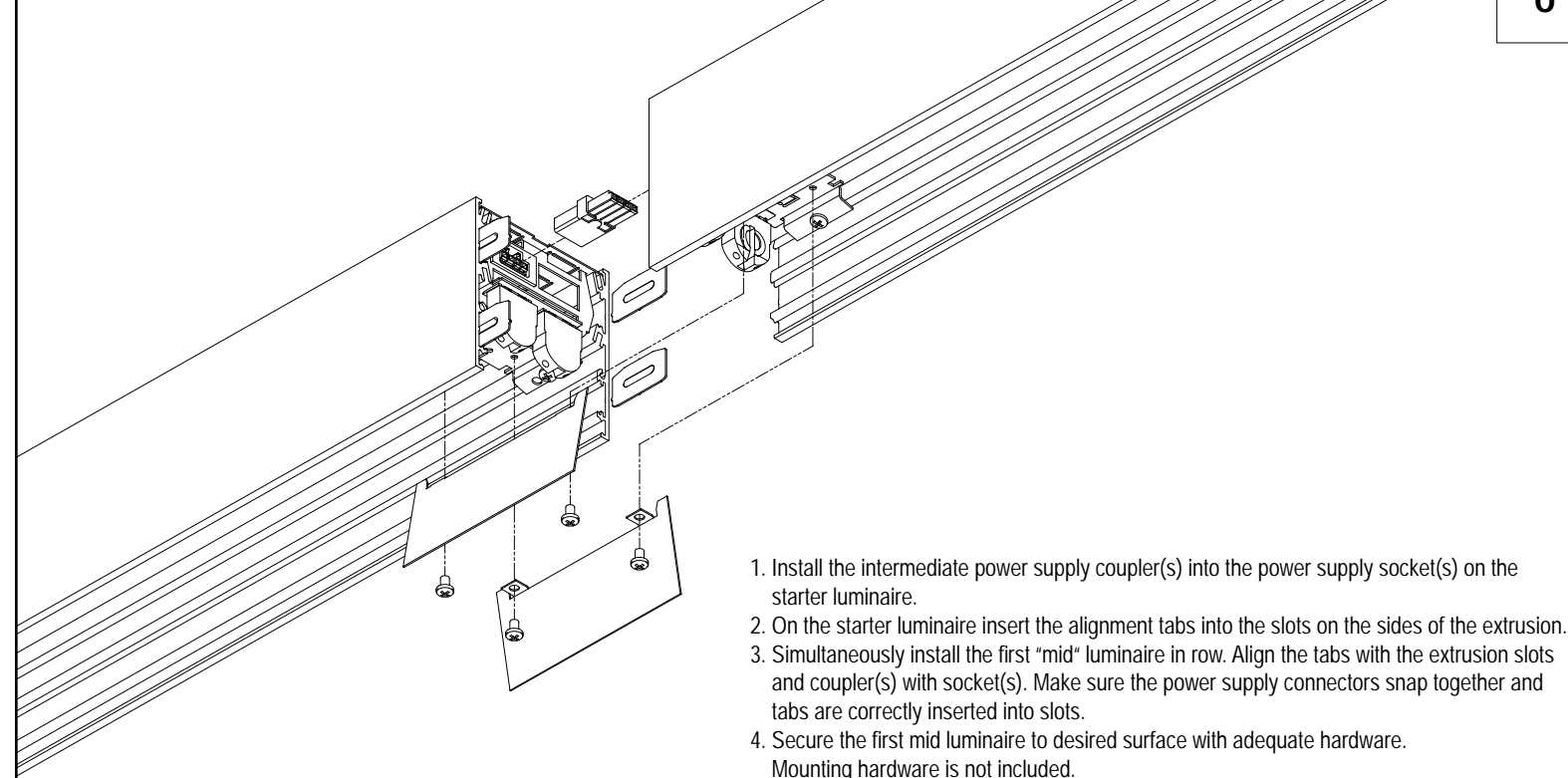

1. Install the intermediate power supply coupler(s) into the power supply socket(s) on the starter luminaire.
2. On the starter luminaire insert the alignment tabs into the slots on the sides of the extrusion.
3. Simultaneously install the first "mid" luminaire in row. Align the tabs with the extrusion slots and coupler(s) with socket(s). Make sure the power supply connectors snap together and tabs are correctly inserted into slots.
4. Secure the first mid luminaire to desired surface with adequate hardware. Mounting hardware is not included.
5. Secure the first mid luminaire to the starter with two joiner brackets and four screws provide. Make sure the tabs on the joiner brackets slide into provided slots on the socket bars.
6. Repeat the steps to finish row installation. Make sure the row ends with the "end" luminaire.